

data sheet single engine two battery bank split charge system

12 volt P2031 part number 12031-300

24 volt P2041 part number 12041-300

contactor current rating

continuous 200 amp @ 40 mV / contact / 100 A
 engine start 400 amp intermittent
 surge 800 amp

operation bi-directional split charge, standard

connect voltage 13.8V / 27.6V
 drop-out voltage 13.0V / 26.0V
 adjustment contactor engagement and drop out
 protection waterproof to IP66

display

type 10 dot bar-graph x 3
 engine battery voltage
 service battery voltage and net amps, charge & discharge
 ammeter shunt 1 integral
 emergency link start ... includes button to engage link start timed period.

system protection . . 3 internal PTC fuses, auto re-set

size / weight

contactor 70 x 60 x 100 mm / 500 gms
 display 100 x 60 x 50 mm / 80 gms

standard pre-fitted options

contact drop-out with engine starter motor operation to protect solar panel and secondary charge systems from high current.
 emergency link start allows engine to be started from service battery bank, timed engagement, remote switch on display.

split charge contactor

The system employs heavy duty contactors, these carry far higher loads than typical VSR relays, making them ideal for emergency engine starting. They also feature a high fault current rupture rating (300 amp to UL508), allowing the disconnection of high current loads at low voltage. The contacts are sealed to IP66, making them suitable for operation in a marine environment, protecting contacts from corrosion and avoiding flash from open contactor units.

emergency link start engages the contacts allowing the engine to be started from the service bank, if the engine battery has a low capacity.

operating voltage settings

Units are supplied normally set to standard voltages, we are happy to set modules to customer requirements, or they can be adjusted on site.

options to order

contact rating 100 and 350 amp
 coil voltages 12 volt DC to 48 volt DC
 fresh water gauge display can be supplied to read fresh water tank level on ammeter bar-graph, includes sensor.
 remote current sensor .. sensor protects the charge system from high loads i.e. inverter use with low service battery level.
 display options digital readout in addition to the standard bar-graph, amps & volts selectable plus engine volts.
 single voltage sense only monitors one contactor terminal, not bi-directional operation.

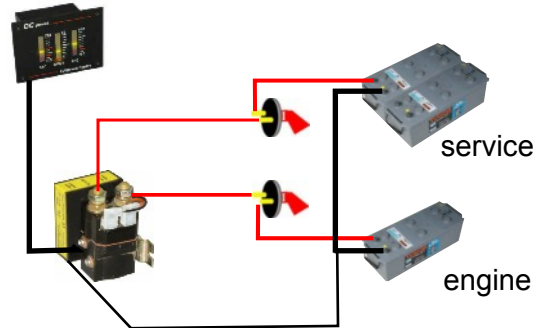

bar-graph

The display allows real time charge monitoring of both volts and amps for all batteries, plus it provides a battery level guide to both battery banks. By employing LED bar-graphs all voltages and amperages can be viewed with out the need for selector switch, or waiting for a display to scroll through. Critical battery voltage levels have red LED's to give visual warning, even when not close to display. The ammeter bar-graphs have a bi-colour LED's that shows polarity of current, green for charge, red for discharge, again providing instant warning if a problem

When charging batteries, the optimum recharge level for a system is when the voltage is at maximum and the current is low, easy to see as the bar-graphs are next to each other. At this point the batteries will not be taking any more significant charge, so motoring for longer is now only consuming fuel and money.

High voltage alarm, drives a audio alarm to indicate high charge voltage level, normally set at 15 volt, other values can be supplied factory set.

The display can be supplied to display the fresh water tank level on the ammeter bar-graph, it only requires the sensor head to be fitted to water tank. The system has the provision to set gauge reading to match the fresh water tank level.

The display only requires connecting a 6 way data cable matching colour to colour, no shunts or cable modifications to alternator wiring are required.

standard display unit full size 100 mm x 60 mm x 50 mm deep

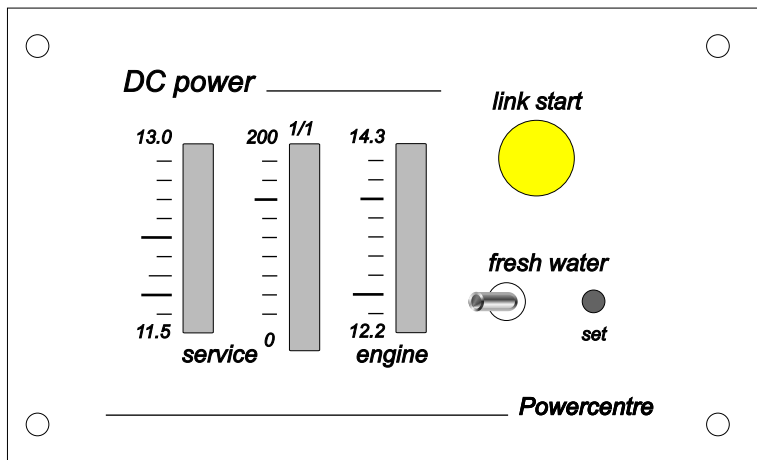

standard display scaling

service V	service A	engine V
12.90	120	14.30
12.75	90	13.65
12.50	60	13.20
12.45	40	12.90
12.30	30	12.65
12.15	20	12.50
12.00	14	12.40
11.85	10	12.30
11.70	8	12.25
11.55	6	12.20

battery level guide
 no load 50% 100%
 on load 50% 100%

red LED

display options

The bar-graph can be supplied to order with alternate display values to suit a particular charging system, see **alternate scaling** allowing the display to be matched to the intended use,

logarithmic scale provides a extended scale in the low half, allowing better low current monitoring of the completion of charge, or current drain during use. While the initial high charge current can be monitored on the upper high section.

linear scale, is used for monitoring charge current, or high discharge loads, the meter scale is uniform over the full meter range.

For non standard options please contact technical section.

alternate display scaling

log scale		linear scale	
60	240	100	200
45	175	90	180
30	125	80	160
20	80	70	140
15	60	60	120
10	40	50	100
7	28	40	80
5	20	30	60
4	16	20	40
3	12	10	20

Digital / bar-graph display full size 175 mm 60 mm x 50 deep

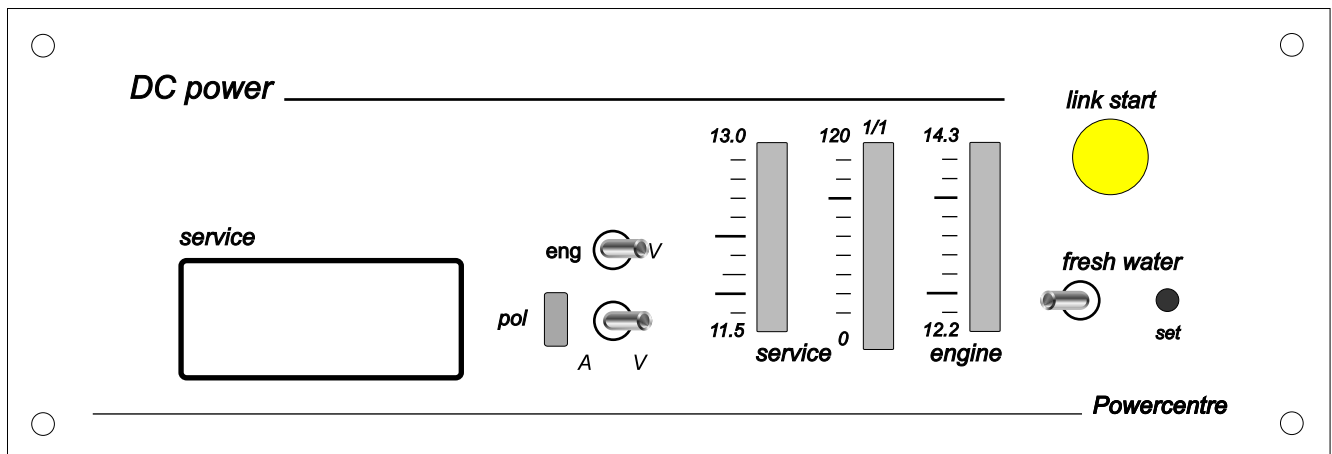

data sheet single engine three battery bank split charge system

12 volt P2131 part number 12131-500

24 volt P2141 part number 12141-500

contactor current rating

continuous 200 amp @ 40 mV / contact / 100 A
 engine start 400 amp intermittent
 surge 800 amp

operation bi-directional split charge, standard
 connect voltage 13.8V / 27.6V bow battery 13.9V/27.8V
 drop-out voltage 13.0V / 26.0V
 adjustment contactor engagement and drop out
 protection waterproof to IP66

display

type 10 dot bar-graph x 5
 engine battery voltage
 service battery voltage and net amps, charge & discharge
 bow battery voltage and charge amps.
 ammeter shunt 2 x Hall effect shunts integral
 emergency link start ... remote button to engage link start timed period.

system protection . . 4 internal PTC fuses, auto re-set

size / weight

contactor 175 x 150 x 135 mm / 1.5 Kg
 display 100 x 60 x 50 mm / 100 gms

standard pre-fitted options

contactor drop-out with engine starter motor operation to protect solar panel and secondary charge systems from high current.
 bow contactor drop out with bow thruster use forces bow thruster to use local battery, avoiding charge system overload.
 emergency link start allows engine to be started from service battery bank, timed engagement, remote switch on display.

split charge contactors

The system employs heavy duty contactors, these carry far higher loads than typical VSR relays, making them ideal for emergency engine starting. They also feature a high fault current rupture rating (300 amp to UL508), allowing the disconnection of high current loads at low voltage. The contacts are sealed to IP66, making them suitable for operation in a marine environment, protecting contacts from corrosion and avoiding flash from open contactor units.

emergency link start allows the engine to be started from the service bank for timed period, if the engine battery has a low capacity.

operating voltage units are normally set to standard switching voltages, we are happy to set modules to customer requirements, or they can be adjusted on site. Alternate voltages can be supplied to order, please contact technical section.

operation initial charge to engine battery, the service battery is connected when battery voltage reaches 13.8 volt, the bow battery in connected at 13.9 volt, batteries are isolated when voltage levels fall to 13.0 volt. The system uses the pulse engagement system first introduced in 1982, with a low battery capacity, on the contactor closing it is held for a period, then disengaged, recharging the engine battery and allowing heat generated within the alternator to disperse, before re-engaging the alternator to a high load. Once the load is within the alternators operating parameters the contactor remains closed.

options to order

contact rating 100 and 350 amp
 coil voltages 12 volt DC to 48 volt DC
 fresh water gauge display can be supplied to read fresh water tank level on ammeter bar-graph, includes sensor.
 remote current sensor .. sensor protects the charge system from high loads i.e. inverter use with low battery level.
 remote bow shunt shunt monitors net charge and discharge for bow battery, it also picks up local battery positive voltage.
 display options digital readout in addition to bar-graph, amps & volts selectable, engine volts, bow batt charge amps & volts

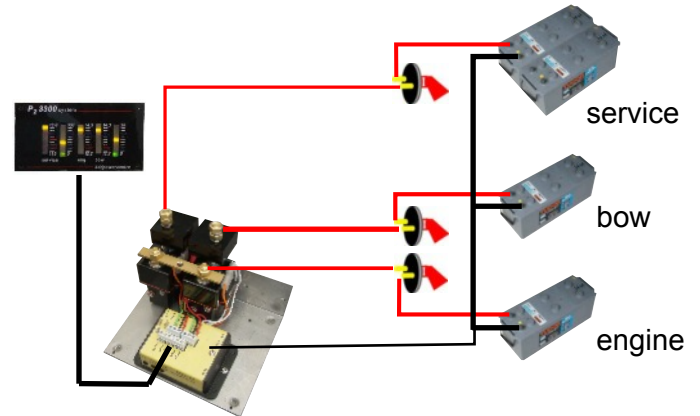

optional display

bar-graph

The display allows real time charge monitoring of both volts and amps for all batteries, plus it provides a battery level guide to both battery banks. By employing LED bar-graphs all voltages and amperages can be viewed with out the need for selector switch, or waiting for a display to scroll through. Critical battery voltage levels have red LED's to give visual warning, even when not close to display. The ammeter bar-graphs have a bi-colour LED's that shows polarity of current, green for charge, red for discharge, again providing instant warning if a problem

When charging batteries, the optimum recharge level for a system is when the voltage is at maximum and the current is low, easy to see as the bar-graphs are next to each other. At this point the batteries will not be taking any more significant charge, so motoring for longer is now only consuming fuel and money.

High voltage alarm, drives a audio alarm to indicate high charge voltage level, normally set at 15 volt, other values can be supplied factory set.

The display can be supplied to display the fresh water tank level on the ammeter bar-graph, it only requires the sensor head to be fitted to water tank. The system has the provision to set gauge reading to match the fresh water tank level.

The display only requires connecting a 6 way data cable matching colour to colour, no shunts or cable modifications required.

standard display unit full size 100 mm x 60 mm x 50 mm deep

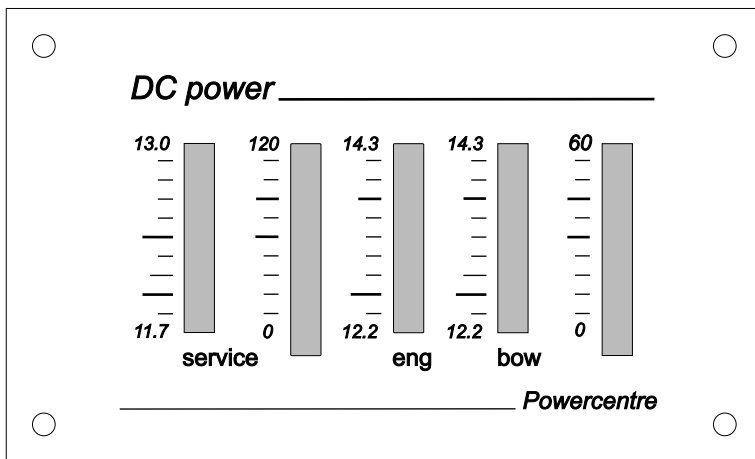

display read-out

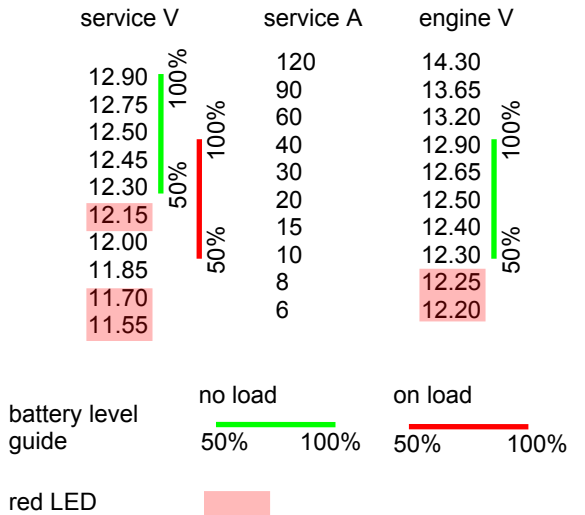

Digital / bar-graph display full size 175 mm 60 mm x 50 deep

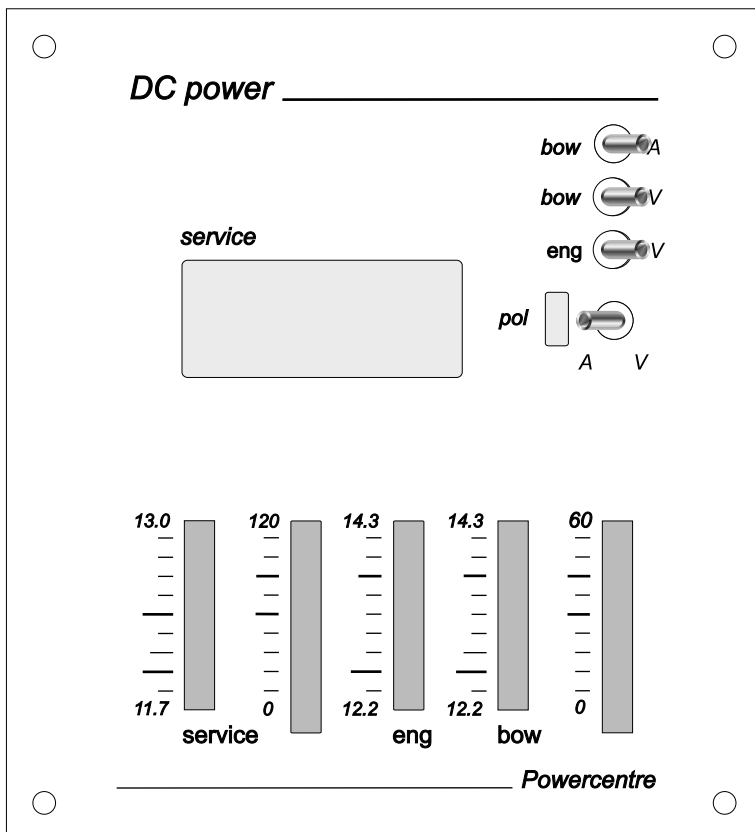

display options

The bar-graph can be supplied to order with alternate display values to suit a particular charging system, see **display options** allowing the display to be matched to the intended use,

logarithmic scale provides a extended scale in the low half, allowing low current monitoring of the completion of charge, or current drain during use. While the high charge current can be monitored on the upper high section.

linear scale, is used for monitoring charge current, or high discharge loads, the meter scale is uniform over the full range.

For non standard options please contact technical section.

alternate display reading

log scale		linear scale	
60	240	100	200
45	175	90	180
30	125	80	160
20	80	70	140
15	60	60	120
10	40	50	100
7	28	40	80
5	20	30	60
4	16	20	40
3	12	10	20

data sheet **single engine four battery bank split charge system**

12 volt P2231 part number 12231-800

24 volt P2241 part number 12241-800

contactor current rating

continuous 200 amp @ 40 mV / contact / 100 A
 engine start 400 amp intermittent
 surge 800 amp

operation bi-directional split charge, standard
 connect voltage 13.8V / 27.6V, 13.9 / 27.8, 13.95 / 27.9
 drop-out voltage 13.0V / 26.0V
 adjustment contactor engagement and drop out
 protection waterproof to IP66

display

type 10 dot bar-graph x 8
 engine battery voltage
 service battery voltage and net amps, charge and discharge
 bow battery voltage charge amps, option charge and discharge
 stern battery voltage charge amps, option charge and discharge.
 Ammeter shunts 3 x Hall effect shunts integral.
 emergency link start ... includes button to engage link start timed period.

system protection .. 5 internal PTC fuses, auto re-set

size / weight

contactor 175 x 150 x 135 mm / 1.9 Kgs
 display 175 x 60 x 50 mm / 100 gms

standard pre-fitted options

contactor drop-out with engine starter motor operation to protect solar panel and secondary charge systems from high current.
 bow contactor drop out with bow thruster use forces bow thruster to use local battery, avoiding charge system overload.
 stern contactor drop out with stern thruster use forces stern thruster to use local battery, avoiding charge system overload.
 emergency link start allows engine to be started from service battery bank, timed engagement, remote switch on display.

split charge contactors

The system employs heavy duty contactors, these carry far higher loads than typical VSR relays, making them ideal for emergency engine starting. They also feature a high fault current rupture rating (300 amp to UL508), allowing the disconnection of high current loads at low voltage. The contacts are sealed to IP66, making them suitable for operation in a marine environment, protecting contacts from corrosion and avoiding flash from open contactor units.

emergency link start allows the engine to be started from the service bank for timed period, if the engine battery has a low capacity.

operating voltage units are normally set to standard switching voltages, we are happy to set modules to customer requirements, or they can be adjusted on site. Alternate voltages can be supplied to order, please contact technical section.

operation initial charge to engine battery, the service battery is connected when battery voltage reaches 13.8 volt, the bow battery in connected at 13.9 volt, stern thruster battery at 13.85 volt batteries are isolated when voltage levels fall to 13.0 volt. The system uses the pulse engagement system first introduced in 1982, with a low battery capacity, on the contactor closing it is held for a period, then disengaged, recharging the engine battery and allowing heat generated within the alternator to disperse, before re-engaging the alternator to a high load. Once the load is within the alternators operating parameters the contactor remains closed.

options to order

contact rating 100 and 350 amp,
 coil voltages 12 volt DC to 48 volt DC
 fresh water gauge display can be supplied to read fresh water tank level on ammeter bar-graph, includes sensor.
 remote current sensor .. sensor protects the charge system from high loads i.e. inverter use with low battery level.
 remote bow shunt shunt monitors net charge and discharge for bow battery, it also picks up local battery positive voltage.
 remote stern shunt shunt monitors net charge and discharge for stern battery, it also picks up local battery positive voltage.
 display options custom display with digital readout in addition to bar-graph, amps & volts.

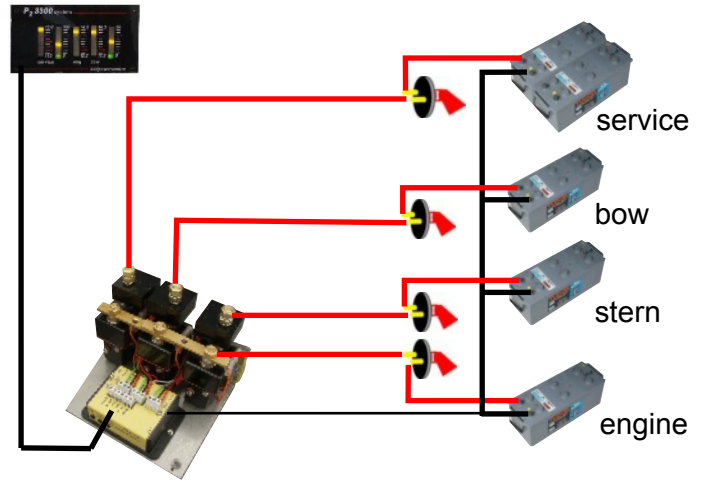

bar-graph

The display allows real time charge monitoring of both volts and amps for all batteries, plus it provides a battery level guide to both battery banks. By employing LED bar-graphs all voltages and amperages can be viewed with out the need for selector switch, or waiting for a display to scroll through. Critical battery voltage levels have red LED's to give visual warning, even when not close to display. The ammeter bar-graphs have a bi-colour LED's that shows polarity of current, green for charge, red for discharge, again providing instant warning if a problem

When charging batteries, the optimum recharge level for a system is when the voltage is at maximum and the current is low, easy to see as the bar-graphs are next to each other. At this point the batteries will not be taking any more significant charge, so motoring for longer is now only consuming fuel and money.

High voltage alarm, drives a audio alarm to indicate high charge voltage level, normally set at 15 volt, other values can be supplied factory set.

The display can be supplied to display the fresh water tank level on the ammeter bar-graph, it only requires the sensor head to be fitted to water tank. The system has the provision to set gauge reading to match the fresh water tank level.

The display only requires connecting a 8 way data cable matching colour to colour, no shunts or cable modifications required.

standard display unit full size 175 mm x 60 mm x 50 mm deep

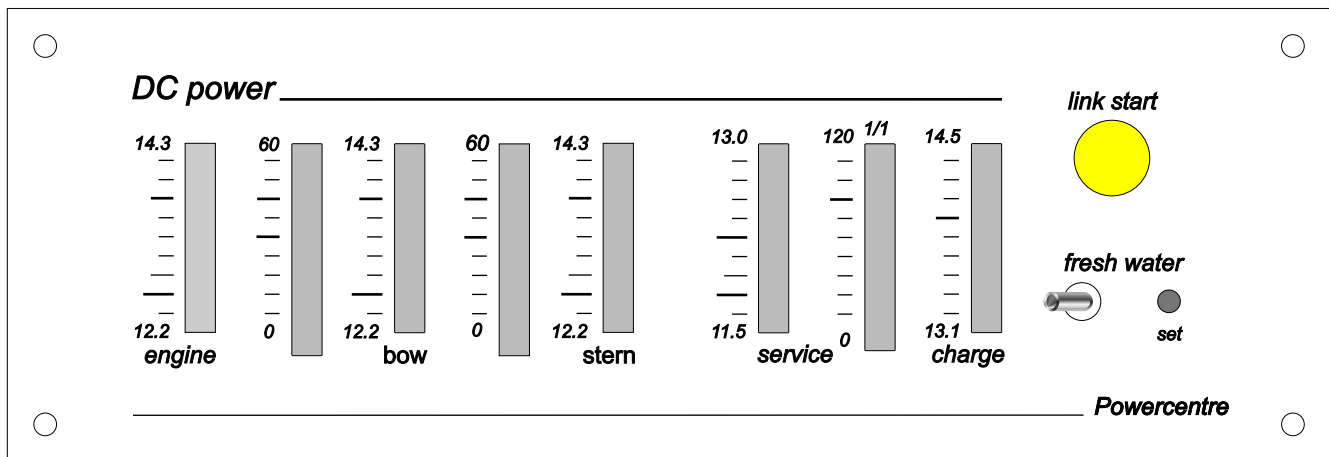

display read-out

service V	service A	engine V	battery level guide	no load	on load
12.90	120	14.30			
12.75	90	13.65	red LED		
12.50	60	13.20			
12.45	40	12.90			
12.30	30	12.65			
12.15	20	12.50			
12.00	14	12.40			
11.85	10	12.30			
11.70	8	12.25			
11.55	6	12.20			

display options

The bar-graph can be supplied to order with alternate display values to suit a particular charging system, see **display options** allowing the display to be matched to the intended use,

logarithmic scale provides a extended scale in the low half, allowing low current monitoring of the completion of charge, or current drain during use. While the initial high high charge current can be monitored on the upper section.

linear scale, is used for monitoring charge current, or high discharge loads, the meter scale is uniform over the full meter range..

digital readout for all functions can be supplied to supplement the bar-graph display, allowing detail examination of volts or amps.

For non standard options please contact technical section.

alternate display scaling

log scale		linear scale	
60	240	100	200
45	175	90	180
30	125	80	160
20	80	70	140
15	60	60	120
10	40	50	100
7	28	40	80
5	20	30	60
4	16	20	40
3	12	10	20

data sheet **single engine, two alternator, three battery bank split charge**

12 volt P2631 part number 12631-500

24 volt P2641 part number 12641-500

contactor current rating

continuous 200 amp @ 40 mV / contact / 100 A
 engine start 400 amp intermittent
 surge 800 amp

operation bi-directional split charge, standard
 connect voltage service constant, bow 13.8V / 27.6V
 drop-out voltage 13.0V / 26.0V
 adjustment contacts engagement and drop out
 protection waterproof to IP66

display

type 10 dot bar-graph x 5
 engine battery voltage
 service battery voltage and net amps, charge & discharge
 bow battery voltage and charge amps to bow battery.
 ammeter shunt integral Hall effect shunt
 emergency link start ... includes button to engage link start timed period.

system protection . . 4 internal PTC fuses, auto re-set

size / weight

contactor 175 x 150 x 135 mm / 1.5 Kgs
 display 100 x 60 x 50 mm / 80 gms

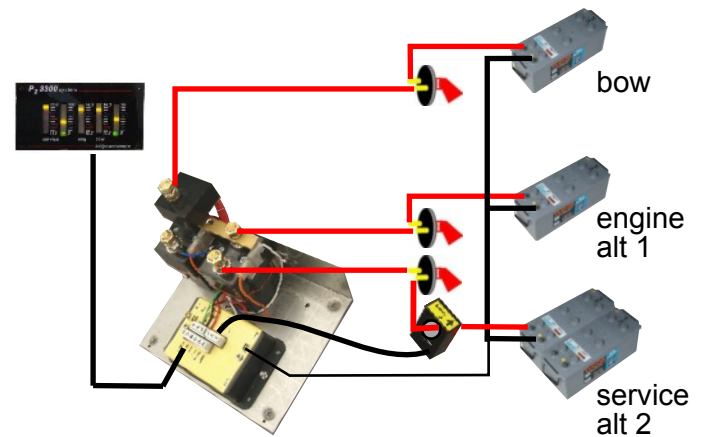

optional display

standard pre-fitted options

bow contactor drop out with bow thruster use forces bow thruster to use local battery, avoiding charge system overload.
 emergency link start allows engine to be started from service battery bank, timed engagement, remote switch on display.

split charge contactors

The system employs heavy duty contactors, these carry far higher loads than typical VSR relays, making them ideal for emergency engine starting. They also feature a high fault current rupture rating (300 amp to UL508), allowing the disconnection of high current loads at low voltage. The contacts are sealed to IP66, making them suitable for operation in a marine environment, protecting contacts from corrosion and avoiding flash from open contactor units.

emergency link start allows the engine to be started from the service bank for timed period, if the engine battery has a low capacity.

operating voltage units are normally set to standard switching voltages, we are happy to set modules to customer requirements, or they can be adjusted on site. Alternate voltages can be supplied to order, please contact technical section.

operation the alternators are split to allow the engine (alt 1) to charge the starter battery and then connects the bow battery, when this reaches a set voltage the second contactor closes to allow charge to service battery. The alternator 2 is permanently connected to the service battery. The system allows for either alternator to charge all the battery banks, thus if one alternator fails, the remaining one will charge all battery banks. A suitable secondary charge source connected to the service battery will charge both engine start and bow battery.

options to order

contact rating 100 and 350 amp
 coil voltage 12 volt DC to 48 volt DC
 fresh water gauge display can be supplied to read fresh water tank level on ammeter bar-graph, includes sensor.
 remote bow shunt Shunt monitors net charge and discharge for bow battery, it also picks up local battery positive voltage.
 display options digital readout in addition to bar-graph, amps & volts selectable, engine volts, bow batt charge amps & volts

bar-graph

The display allows real time charge monitoring of both volts and amps for all batteries, plus it provides a battery level guide to both battery banks. By employing LED bar-graphs all voltages and amperages can be viewed with out the need for selector switch, or waiting for a display to scroll through. Critical battery voltage levels have red LED's to give visual warning, even when not close to display. The ammeter bar-graphs have a bi-colour LED's that shows polarity of current, green for charge, red for discharge, again providing instant warning if a problem

When charging batteries, the optimum recharge level for a system is when the voltage is at maximum and the current is low, easy to see as the bar-graphs are next to each other. At this point the batteries will not be taking any more significant charge, so motoring for longer is now only consuming fuel and money.

High voltage alarm, drives a audio alarm to indicate high charge voltage level, normally set at 15 volt, other values can be supplied factory set.

The display can be supplied to display the fresh water tank level on the ammeter bar-graph, it only requires the sensor head to be fitted to water tank. The system has the provision to set gauge reading to match the fresh water tank level.

The display only requires connecting a 6 way data cable matching colour to colour, no shunts or cable modifications required.

standard display unit full size 100 mm x 60 mm x 50 mm deep

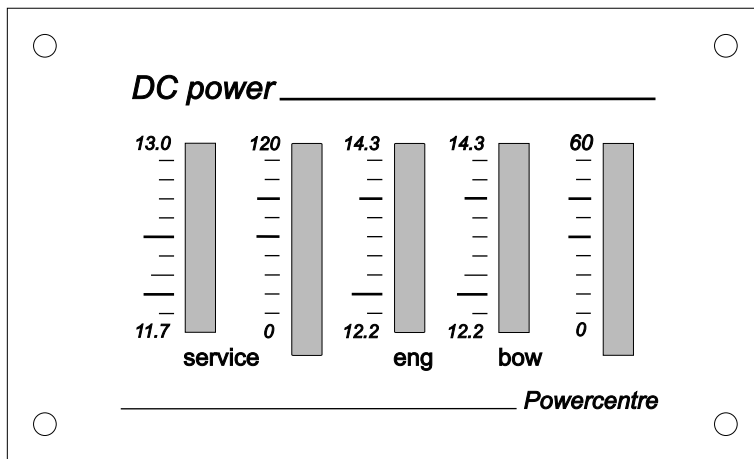

display read-out

service V	service A	engine V
12.90	120	14.30
12.75	90	13.65
12.50	60	13.20
12.45	40	12.90
12.30	30	12.65
12.15	20	12.50
12.00	14	12.40
11.85	10	12.30
11.70	8	12.25
11.55	6	12.20

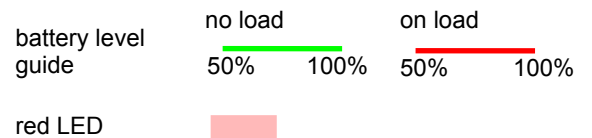

Digital / bar-graph display full size 175 mm 60 mm x 50 deep

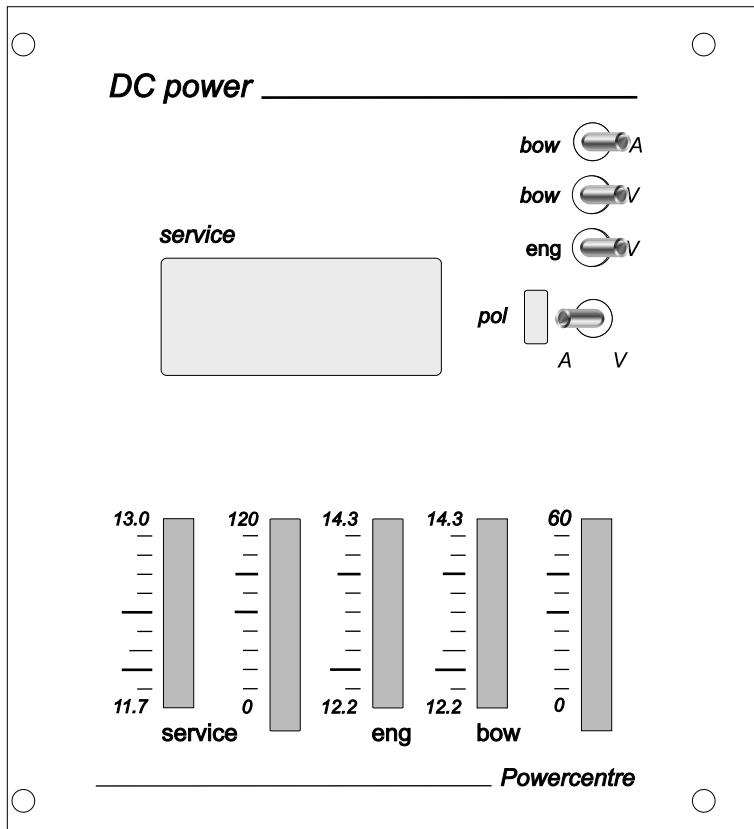

display options

The bar-graph can be supplied to order with alternate display values to suit a particular charging system, see **display options** allowing the display to be matched to the intended use,

logarithmic scale provides a extended scale in the low half, allowing low current monitoring of the completion of charge, or current drain during use. While the initial high charge current can be monitored on the upper high section.

linear scale, is used for monitoring charge current, or high discharge loads, the meter scale is uniform over the full meter scale.

For non standard options please contact technical section.

alternate display reading

log scale		linear scale	
60	240	100	200
44	175	90	180
31	125	80	160
20	80	70	140
15	60	60	120
10	40	50	100
7	28	40	80
5	20	30	60
4	16	20	40
3	12	10	20

data sheet **single engine, two alternator, four battery bank split charge**

12 volt P2731 part number 12731-800

24 volt P2741 part number 12741-800

contactor current rating

continuous 200 amp @ 40 mV / contact / 100 A
 engine start 400 amp intermittent
 surge 800 amp

operation

..... bi-directional split charge, standard
 connect voltage bow .. 13.8V / 27.6V stern 13.9V / 27.8V
 drop-out voltage 13.0V / 26.0V
 adjustment contactor engagement and drop out
 protection waterproof to IP66

display

type 10 dot bar-graph x 8
 engine battery voltage
 service battery voltage and net amps, charge & discharge
 emergency link start ... includes button to engage link start timed period.

system protection

..... 5 internal PTC fuses, auto re-set

size / weight

contactor 175 x 140 x 135 mm / 1.9 Kgs
 display 175 x 60 x 50 mm / 100 gms

standard pre-fitted options

bow contactor drop out with bow thruster use forces bow thruster to use local battery, avoiding charge system overload.
 stern contactor drop out with stern thruster use forces stern thruster to use local battery, avoiding charge system overload.
 emergency link start allows engine to be started from service battery bank, timed engagement, remote switch.

split charge contactors

The system employs heavy duty contactors, these carry far higher loads than typical VSR relays, making them ideal for emergency engine starting. They also feature a high fault current rupture rating (300 amp to UL508), allowing the disconnection of high current loads at low voltage. The contacts are sealed to IP66, making them suitable for operation in a marine environment, protecting contacts from corrosion and avoiding flash from open contactor units.

emergency link start allows the engine to be started from the service bank for timed period, if the engine battery has a low capacity.

operating voltage units are normally set to standard switching voltages, we are happy to set modules to customer requirements, or they can be adjusted on site. Alternate voltages can be supplied to order, please contact technical section.

operation the alternators are split to allow the engine (alt 1) to charge the starter battery and then connects the bow battery at 13.8 volt, then the stern battery at 13.9 volt, when this reaches a set voltage the third contactor closes to allow charge to the service battery. The alternator 2 is permanently connected to the service battery. The system allows for either alternator to charge all the battery banks, thus if one alternator fails, the remaining one will charge all battery banks. A suitable secondary charge source connected to the service battery can charge both engine start and bow battery.

options to order

contact rating 100 and 350 amp
 coil 12 volt DC to 48 volt DC
 fresh water gauge display can be supplied to read fresh water tank level on ammeter bar-graph, includes sensor.
 remote bow shunt shunt monitors net charge and discharge for bow battery, it also picks up local battery positive voltage.
 remote stern shunt shunt monitors net charge and discharge for stern battery, it also picks up local battery positive voltage.
 display options custom display with digital readout in addition to bar-graph, amps & volts.

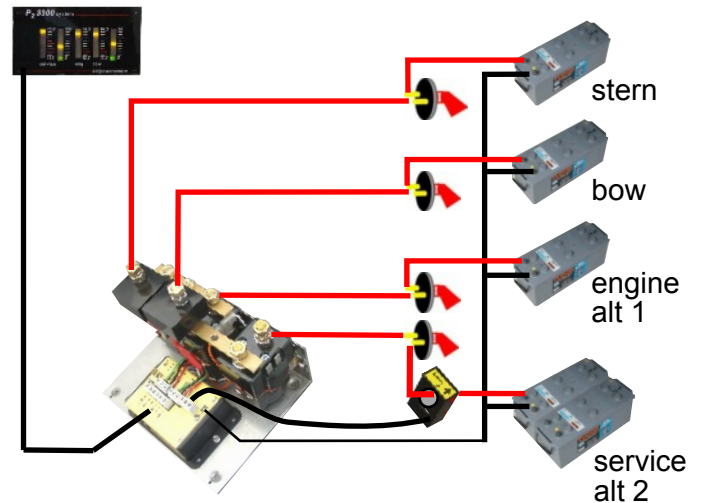

bar-graph

The display allows real time charge monitoring of both volts and amps for all batteries, plus it provides a battery level guide to both battery banks. By employing LED bar-graphs all voltages and amperages can be viewed with out the need for selector switch, or waiting for a display to scroll through. Critical battery voltage levels have red LED's to give visual warning, even when not close to display. The ammeter bar-graphs have a bi-colour LED's that shows polarity of current, green for charge, red for discharge, again providing instant warning if a problem

When charging batteries, the optimum recharge level for a system is when the voltage is at maximum and the current is low, easy to see as the bar-graphs are next to each other. At this point the batteries will not be taking any more significant charge, so motoring for longer is now only consuming fuel and money.

High voltage alarm, drives a audio alarm to indicate high charge voltage level, normally set at 15 volt, other values can be supplied factory set.

The display can be supplied to display the fresh water tank level on the ammeter bar-graph, it only requires the sensor head to be fitted to water tank. The system has the provision to set gauge reading to match the fresh water tank level.

The display only requires connecting a 8 way data cable matching colour to colour, no shunts or cable modifications required.

standard display unit full size 175 mm x 60 mm x 50 mm deep

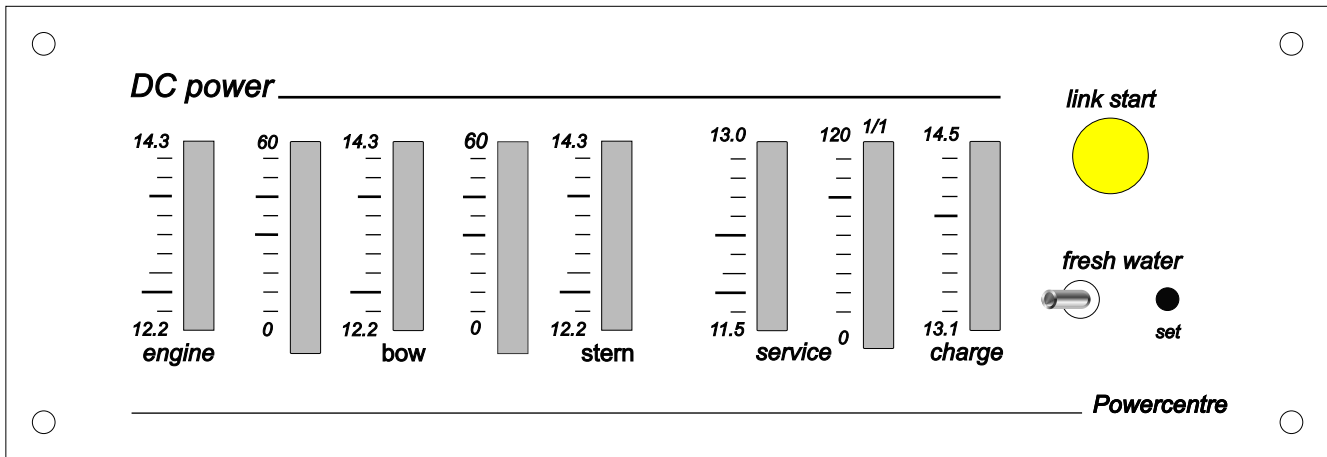

display read-out

service V	service A	engine V	battery level guide	no load	on load
12.90	120	14.30		50%	50%
12.75	90	13.65		100%	100%
12.50	60	13.20	red LED		
12.45	40	12.90			
12.30	30	12.65			
12.15	20	12.50			
12.00	14	12.40			
11.85	10	12.30			
11.70	8	12.25			
11.55	6	12.20			

display options

The bar-graph can be supplied to order with alternate display values to suit a particular charging system, see **display options** allowing the display to be matched to the intended use,

logarithmic scale provides a extended scale in the low half, allowing low current monitoring of the completion of charge, or current drain during use. While the initial high charge current can be monitored on the upper high section.

linear scale, is used for monitoring charge current, or high discharge loads, the meter scale is uniform ove the full meter range.

digital readout for all functions can be supplied to supplement the bar-graph display, allowing detail examination of volts or amps.

For non standard options please contact technical section.

alternate display scaling

log scale		linear scale	
60	240	100	200
45	175	90	180
30	125	80	160
20	80	70	140
15	60	60	120
10	40	50	100
7	28	40	80
5	20	30	60
4	16	20	40
3	12	10	20

data sheet twin engine two battery bank split charge system

12 volt P2331 part number 12331-300

24 volt P2341 part number 12341-300

contactor current rating

continuous 200 amp @ 40 mV / contact / 100 A
 engine start 400 amp intermittent
 surge 800 amp

operation bi-directional split charge, standard

connect voltage 13.8V / 27.6V
 drop-out voltage 13.0V / 26.0V
 adjustment contactor engagement and drop out
 protection waterproof to IP66

display

type 10 dot bar-graph x 3
 engine battery voltage
 service battery voltage and net amps, charge & discharge
 Ammeter shunt 1 x Hall effect effect shunt fitted.
 emergency link start ... includes button to engage link start timed period.

system protection . . 3 internal PTC fuses, auto re-set

size / weight

contactor 70 x 60 x 100 mm / 500 gms
 display 100 x 60 x 50 mm / 80 gms

standard pre-fitted options

emergency link start allows either engine to be started from either battery bank, timed engagement, remote switch on display.

split charge contactor

The system employs heavy duty contactors, these carry far higher loads than typical VSR relays, making them ideal for emergency engine starting. They also feature a high fault current rupture rating (300 amp to UL508), allowing the disconnection of high current loads at low voltage. The contacts are sealed to IP66, making them suitable for operation in a marine environment, protecting contacts from corrosion and avoiding flash from open contactor units.

emergency link start engages the contacts allowing the engine to be started from the service bank, if the engine battery has a low capacity.

operating voltage

Units are supplied normally set to standard voltages, we are happy to set modules to customer requirements, or they can be adjusted on site. Alternate can be supplied 12 or 24 volt operation to order, for other values please contact technical section.

operation

the system allows the engine that supplies no load, to link and supplement charging to the service battery. It is common with the high demands for electric power on modern motorboats, for the alternator never to reach regulation voltage. This results in the service battery never being fully charged, by linking both alternators to the service bank a higher voltage, thus charge level achieved. A secondary feature is that if either alternator fails, the remaining one will charge both battery banks.

options to order

contact rating 100 and 350 amp
 coil voltages 12 volt Dc to 48 volt DC
 fresh water gauge display can be supplied to read fresh water tank level on ammeter bar-graph, includes sensor.
 display options digital readout in addition to the standard bar-graph, amps & volts selectable plus engine volts.

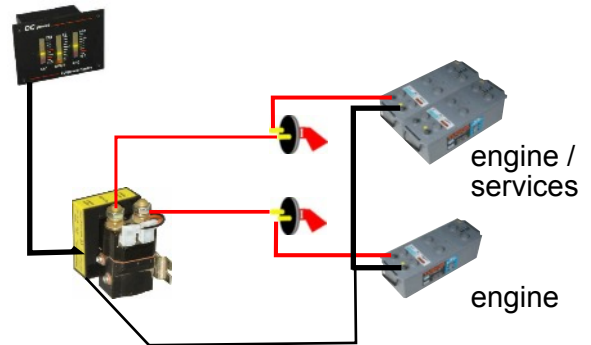

bar-graph

The display allows real time charge monitoring of both volts and amps for all batteries, plus it provides a battery level guide to both battery banks. By employing LED bar-graphs all voltages and amperages can be viewed with out the need for selector switch, or waiting for a display to scroll through. Critical battery voltage levels have red LED's to give visual warning, even when not close to display. The ammeter bar-graphs have a bi-colour LED's that shows polarity of current, green for charge, red for discharge, again providing instant warning if a problem

When charging batteries, the optimum recharge level for a system is when the voltage is at maximum and the current is low, easy to see as the bar-graphs are next to each other. At this point the batteries will not be taking any more significant charge, so motoring for longer is now only consuming fuel and money.

High voltage alarm, drives a audio alarm to indicate high charge voltage level, normally set at 15 volt, other values can be supplied factory set.

The display can be supplied to display the fresh water tank level on the ammeter bar-graph, it only requires the sensor head to be fitted to water tank. The system has the provision to set gauge reading to match the fresh water tank level.

The display only requires connecting a 6 way data cable matching colour to colour, no shunts or cable modifications required.

standard display unit full size 100 mm x 60 mm x 50 mm deep

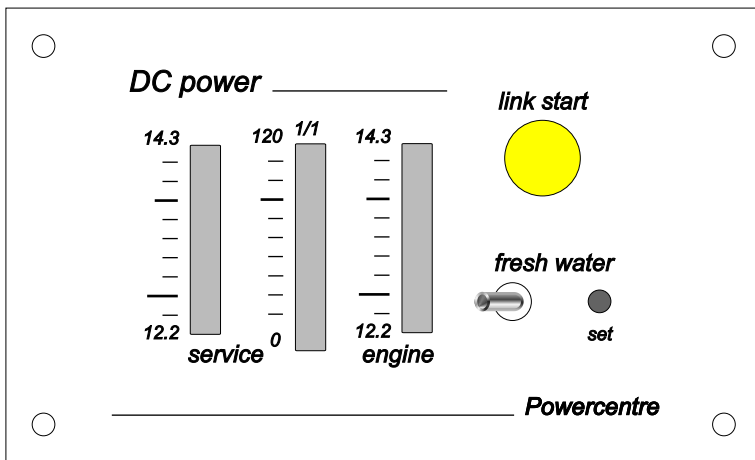

display read-out

service V	service A	engine V
12.90	120	14.30
12.75	90	13.65
12.50	60	13.20
12.45	40	12.90
12.30	30	12.65
12.15	20	12.50
12.00	14	12.40
11.85	10	12.30
11.70	8	12.25
11.55	6	12.20

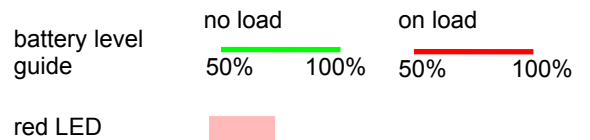

display options

The bar-graph can be supplied to order with alternate display values to suit a particular charging system, see **display options** allowing the display to be matched to the intended use,

logarithmic scale provides an extended scale in the low half, allowing low current monitoring of the completion of charge, or current drain during use. While the initial high charge current can be monitored on the upper section.

linear scale, is used for monitoring charge current, or high discharge loads, the meter scale is uniform over the full meter range.

For non standard options please contact technical section.

alternate display scaling

log scale		linear scale	
60	240	100	200
45	175	90	180
30	125	80	160
20	80	70	140
15	60	60	120
10	40	50	100
7	28	40	80
5	20	30	60
4	16	20	40
3	12	10	20

digital / bar-graph display full size 175 mm 60 mm x 50 deep

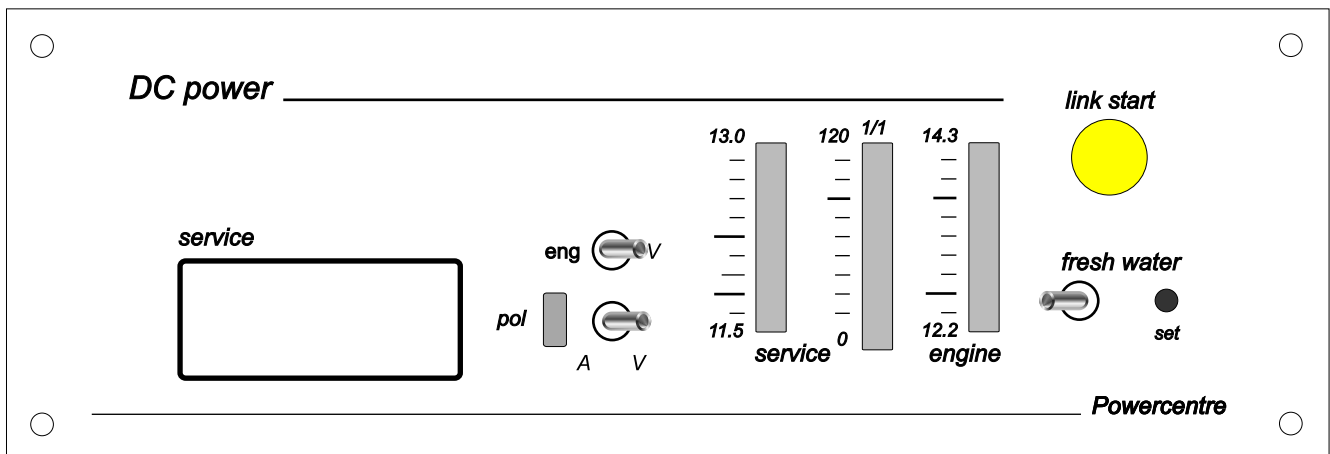

data sheet twin engine three battery bank split charge system

12 volt P2431 part number 12431-400

24 volt P2441 part number 12441-400

contactor current rating

continuous 200 amp @ 40 mV / contact / 100 A
 engine start 400 amp intermittent
 surge 800 amp

operation

..... bi-directional split charge, standard
 connect voltage 13.8V / 27.6V
 drop-out voltage 13.0V / 26.0V
 adjustment relay engagement and drop out
 protection waterproof to IP66

display

type 10 dot bar-graph x 4
 engine battery voltage 2
 service battery voltage and net amps, charge & discharge
 ammeter shunt 1 integral hall effect shunt
 emergency link start ... includes button to engage link start timed period.

system protection

..... 4 internal PTC fuses, auto re-set

size / weight

contactor 175 x 150 x 135 mm / 1.5 Kgs

display 100 x 60 x 50 mm / 80 gms

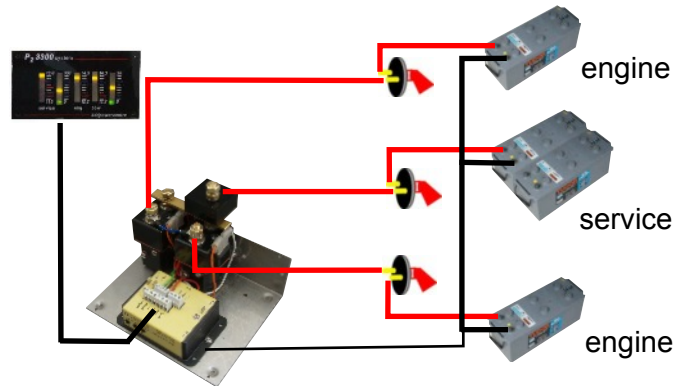

standard pre-fitted options

contact drop-out with engine starter motor operation to protect solar panel and secondary charge systems from high current.
 emergency link start allows engine to be started from service battery bank, timed engagement, remote switch on display.

split charge contactor

The system employs heavy duty contactors, these carry far higher loads than typical VSR relays, making them ideal for emergency engine starting. They also feature a high fault current rupture rating (300 amp to UL508), allowing the disconnection of high current loads at low voltage. The contacts are sealed to IP66, making them suitable for operation in a marine environment, protecting contacts from corrosion and avoiding flash from open contactor units.

emergency link start engages the contacts allowing the engine to be started from the service bank, if the engine battery has a low capacity.

operating voltage

Units are supplied normally set to standard voltages, we are happy to set modules to customer requirements, or they can be adjusted on site. Alternate can be supplied 12 or 24 volt operation to order, for other values please contact technical section.

operation

The system allows both engines to charge separate engine start batteries, when a set voltage is reached the contactors are closed and the service battery charged by both alternators, contactors drop out at a set low voltage. If the boat is fitted with an inverter it can be monitored for operation, dropping out the contactors to prevent damage to the charging system due to high load being drawn from the engine battery due to low service battery. If one alternator fails, the remaining one will charge all battery banks via charge contactors

options to order

contact rating 100 and 350 amp
 coil rating 12 volt DC to 48 volt DC
 fresh water gauge display can be supplied to read fresh water tank level on ammeter bar-graph, includes sensor.
 remote current sensor .. sensor protects the charge system from high loads i.e. inverter use with low battery level.
 display options digital readout in addition to the standard bar-graph, amps & volts selectable plus engine volts.

bar-graph

The display allows real time charge monitoring of both volts and amps for all batteries, plus it provides a battery level guide to both battery banks. By employing LED bar-graphs all voltages and amperages can be viewed with out the need for selector switch, or waiting for a display to scroll through. Critical battery voltage levels have red LED's to give visual warning, even when not close to display. The ammeter bar-graphs have a bi-colour LED's that shows polarity of current, green for charge, red for discharge, again providing instant warning if a problem

When charging batteries, the optimum recharge level for a system is when the voltage is at maximum and the current is low, easy to see as the bar-graphs are next to each other. At this point the batteries will not be taking any more significant charge, so motoring for longer is now only consuming fuel and money.

High voltage alarm, drives a audio alarm to indicate high charge voltage level, normally set at 15 volt, other values can be supplied factory set.

The display can be supplied to display the fresh water tank level on the ammeter bar-graph, it only requires the sensor head to be fitted to water tank. The system has the provision to set gauge reading to match the fresh water tank level.

The display only requires connecting a 6 way data cable matching colour to colour, no shunts or cable modifications required.

standard display unit full size 100 mm x 60 mm x 50 mm deep

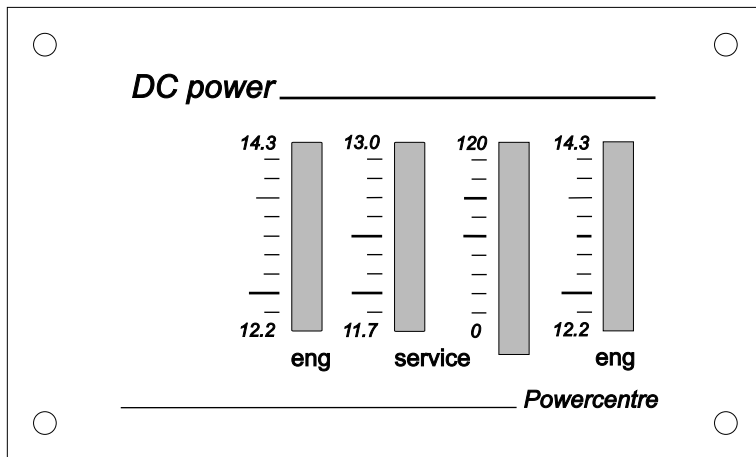

display read-out

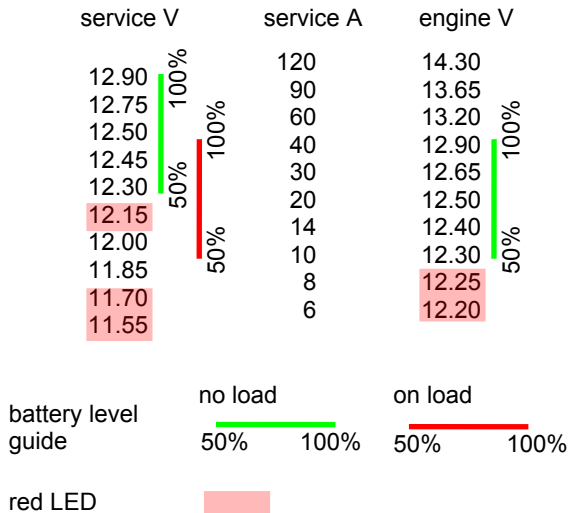

display options

The bar-graph can be supplied to order with alternate display values to suit a particular charging system, see **display options** allowing the display to be matched to the intended use,

logarithmic scale provides a extended scale in the low half, allowing low current monitoring of the completion of charge, or current drain during use. While the initial high charge current can be monitored on the upper high section.

linear scale, is used for monitoring charge current, or high discharge loads, the meter scale is uniform over the full meter range.

For non standard options please contact technical section.

Digital / bar-graph display full size 175 mm 60 mm x 50 deep

alternate display scaling

log scale		linear scale	
60	240	100	200
45	175	90	180
30	125	80	160
20	80	70	140
15	60	60	120
10	40	50	100
7	28	40	80
5	20	30	60
4	16	20	40
3	12	10	20

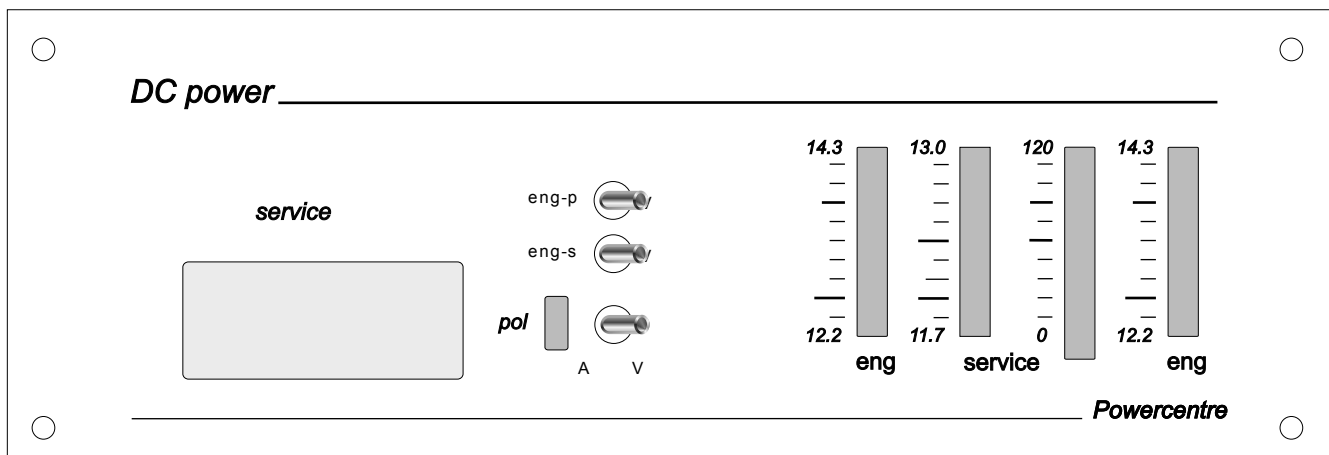

data sheet twin engine four battery bank split charge system

12 volt P2531 part number 12531-600

24 volt P2541 part number 12541-600

contactor current rating

continuous 200 amp @ 40 mV / contact / 100 A
 engine start 400 amp intermittent
 surge 800 amp

operation

..... bi-directional split charge, standard
 connect voltage 13.8V / 27.6V
 drop-out voltage 13.0V / 26.0V
 adjustment contactor engagement and drop out
 protection waterproof to IP66

display

type 10 dot bar-graph x 6
 engine battery voltage
 service battery voltage and net amps, charge & discharge
 bow battery voltage and charge amps
 ammeter shunt 2 integral Hall effect shunts
 emergency link start ... includes button to engage link start timed period.

system protection

..... 5 internal PTC fuses, auto re-set

size / weight
 contactor 175 x 150 x 135 mm / 500 gms
 display 175 x 60 x 50 mm / 80 gms

standard pre-fitted options

contactor drop-out with engine starter motor operation to protect solar panel and secondary charge systems from high current.
 contactor drop-out with bow thruster operation forces bow thruster to use local battery, avoids charge system overload.
 emergency link start allows engine with low battery to start from good engine battery, maintains clean service power supply, .

split charge contactor

The system employs heavy duty contactors, these carry far higher loads than typical VSR relays, making them ideal for emergency engine starting. They also feature a high fault current rupture rating (300 amp to UL508), allowing the disconnection of high current loads at low voltage. The contacts are sealed to IP66, making them suitable for operation in a marine environment, protecting contacts from corrosion and avoiding flash from open contactor units.

emergency link start engages the contacts allowing the engine to be started from the service bank, if the engine battery has a low capacity.

operating voltage

Units are supplied normally set to standard voltages, we are happy to set modules to customer requirements, or they can be adjusted on site. Alternate can be supplied 12 or 24 volt operation to order, for other values please contact technical section.

operation

The system allows both engines to charge separate engine start batteries, when a set voltage is reached the contactors are closed and the service battery charged by both alternators, contactors drop out at a set low voltage. Both bow thruster and inverter can be monitored for operation, dropping out the contactors to prevent damage to the charging system due to high load being drawn from the engine battery due to low service or bow battery. If one alternator fails, the remaining one will charge all battery banks

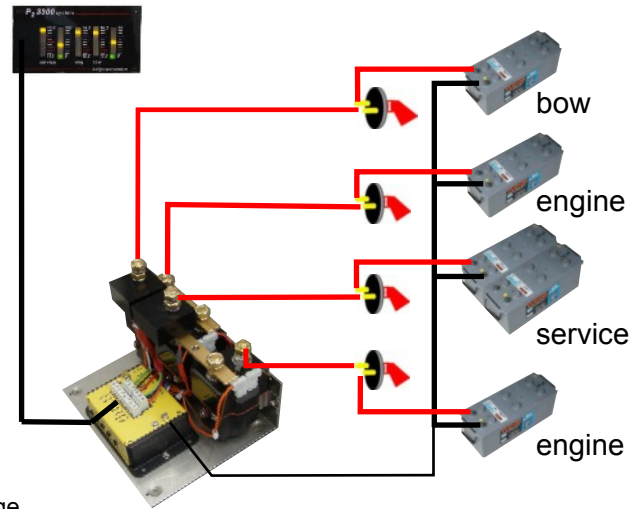

options to order

contact rating 100 and 350 amp
 coil voltages 12 volt DC to 48 volt DC
 fresh water gauge x 2 ... display can be supplied to read 2 x fresh water tank levels on ammeter bar-graphs, includes sensors.
 remote current sensor .. sensor protects the charge system from high loads i.e. inverter use with low service battery levels.
 remote current shunt monitors charge and load on bow thruster battery, plus local battery positive voltage.
 display options digital readout in addition to the standard bar-graph, amps & volts selectable.
 link start option for internal or external emergency link start contactor,

bar-graph

The display allows real time charge monitoring of both volts and amps for all batteries, plus it provides a battery level guide to both battery banks. By employing LED bar-graphs all voltages and amperages can be viewed with out the need for selector switch, or waiting for a display to scroll through. Critical battery voltage levels have red LED's to give visual warning, even when not close to display. The ammeter bar-graphs have a bi-colour LED's that shows polarity of current, green for charge, red for discharge, again providing instant warning if a problem

When charging batteries, the optimum recharge level for a system is when the voltage is at maximum and the current is low, easy to see as the bar-graphs are next to each other. At this point the batteries will not be taking any more significant charge, so motoring for longer is now only consuming fuel and money.

High voltage alarm, drives a audio alarm to indicate high charge voltage level, normally set at 15 volt, other values can be supplied factory set.

The display can be supplied to display the fresh water tank level on the ammeter bar-graph, it only requires the sensor head to be fitted to water tank. The system has the provision to set gauge reading to match the fresh water tank level.

The display only requires connecting a 8 way data cable matching colour to colour, no shunts or cable modifications required.

standard display unit full size 175 mm x 60 mm x 50 mm deep

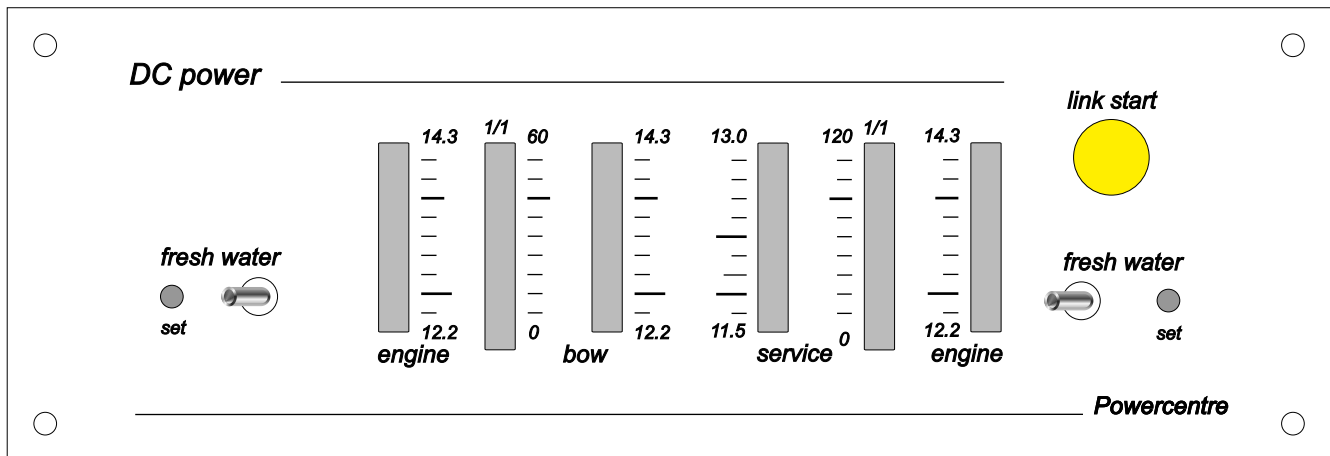

display read-out

service V	service A	engine V	battery level guide
12.90	120	14.30	no load 50% 100%
12.75	90	13.65	on load 50% 100%
12.50	60	13.20	red LED
12.45	40	12.90	
12.30	30	12.65	
12.15	20	12.50	
12.00	14	12.40	
11.85	10	12.30	
11.70	8	12.25	
11.55	6	12.20	

display options

The bar-graph can be supplied to order with alternate display values to suit a particular charging system, see **display options** allowing the display to be matched to the intended use,

logarithmic scale provides a extended scale in the low half, allowing low current monitoring of the completion of charge, or current drain during use, While the initial high charge current can be monitored on the upper high section.

linear scale, is used for monitoring charge current, or high discharge loads, the meter scale is uniform over the full meter range..

For non standard options please contact technical section.

alternate display reading

log scale		linear scale	
60	240	100	200
45	175	90	180
30	125	80	160
20	80	70	140
15	60	60	120
10	40	50	100
7	28	40	80
5	20	30	60
4	16	20	40
3	12	10	20

data sheet twin engine, four bank, start, service, bow and stern

12 volt P2831 part number 12731-800

24 volt P2841 part number 12741-800

contactor current rating

continuous 200 amp @ 40 mV / contact / 100 A
 engine start 400 amp intermittent
 surge 800 amp

operation

..... bi-directional split charge, standard
 connect voltage bow .. 13.8V / 27.6V stern 13.9V / 27.8V
 drop-out voltage 13.0V / 26.0V
 adjustment contactor engagement and drop out
 protection waterproof to IP66

display

type 10 dot bar-graph x 8
 engine battery voltage
 service battery voltage and net amps, charge & discharge
 bow battery voltage and charge amps.
 stern battery voltage and charge amps.
 ammeter shunts 3 integral Hall effect shunts
 emergency link start ... includes button to engage link start timed period.

system protection

..... 5 internal PTC fuses, auto re-set

size / weight

contactor 175 x 140 x 135 mm / 1.9 Kgs

display 175 x 60 x 50 mm / 100 gms

standard pre-fitted options

bow contactor drop out with bow thruster use forces bow thruster to use local battery, avoiding charge system overload.
 stern contactor drop out with stern thruster use forces stern thruster to use local battery, avoiding charge system overload.
 emergency link start allows engine to be started from service battery bank, timed engagement, remote switch.

split charge contactors

The system employs heavy duty contactors, these carry far higher loads than typical VSR relays, making them ideal for emergency engine starting. They also feature a high fault current rupture rating (300 amp to UL508), allowing the disconnection of high current loads at low voltage. The contacts are sealed to IP66, making them suitable for operation in a marine environment, protecting contacts from corrosion and avoiding flash from open contactor units.

emergency link start allows the engine to be started from the service bank for timed period, if the engine battery has a low capacity.

operating voltage units are normally set to standard switching voltages, we are happy to set modules to customer requirements, or they can be adjusted on site. Alternate voltages can be supplied to order, please contact technical section.

Operation the engines are wired to allow both engines to start from a single battery bank, the alternators are split to allow the engine 1 (alt 1) to charge the starter battery bank and then connects the bow battery at 13.8 volt, then the stern battery at 13.9 volt, when this reaches a set voltage the third contactor closes to allow charge to the service battery. The engine 2 alternator is permanently connected to the service battery. The system allows for either alternator to charge all the battery banks, thus if one alternator fails, the remaining one will charge all battery banks. A suitable secondary charge source connected to the service battery bank can charge both engine start, bow and stern battery.

options to order

contact rating 100 and 350 amp

coil voltage 12 volt DC to 48 volt DC

fresh water gauge display can be supplied to read fresh water tank level on ammeter bar-graph, includes sensor.

remote bow shunt shunt monitors net charge and discharge for bow battery, it also picks up local battery positive voltage.

remote stern shunt shunt monitors net charge and discharge for stern battery, it also picks up local battery positive voltage.

display options custom display with digital readout in addition to bar-graph, amps & volts.

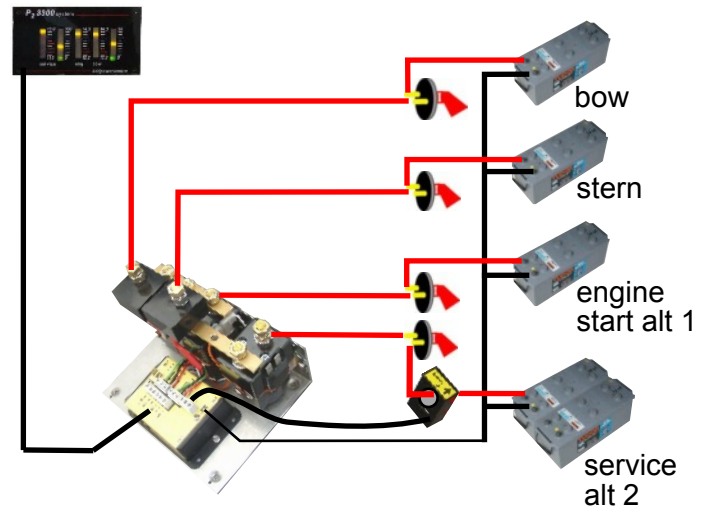

bar-graph

The display allows real time charge monitoring of both volts and amps for all batteries, plus it provides a battery level guide to both battery banks. By employing LED bar-graphs all voltages and amperages can be viewed with out the need for selector switch, or waiting for a display to scroll through. Critical battery voltage levels have red LED's to give visual warning, even when not close to display. The ammeter bar-graphs have a bi-colour LED's that shows polarity of current, green for charge, red for discharge, again providing instant warning if a problem

When charging batteries, the optimum recharge level for a system is when the voltage is at maximum and the current is low, easy to see as the bar-graphs are next to each other. At this point the batteries will not be taking any more significant charge, so motoring for longer is now only consuming fuel and money.

High voltage alarm, drives a audio alarm to indicate high charge voltage level, normally set at 15 volt, other values can be supplied factory set.

The display can be supplied to display the fresh water tank level on the ammeter bar-graph, it only requires the sensor head to be fitted to water tank. The system has the provision to set gauge reading to match the fresh water tank level.

The display only requires connecting a 8 way data cable matching colour to colour, no shunts or cable modifications required.

standard display unit full size 175 mm x 60 mm x 50 mm deep

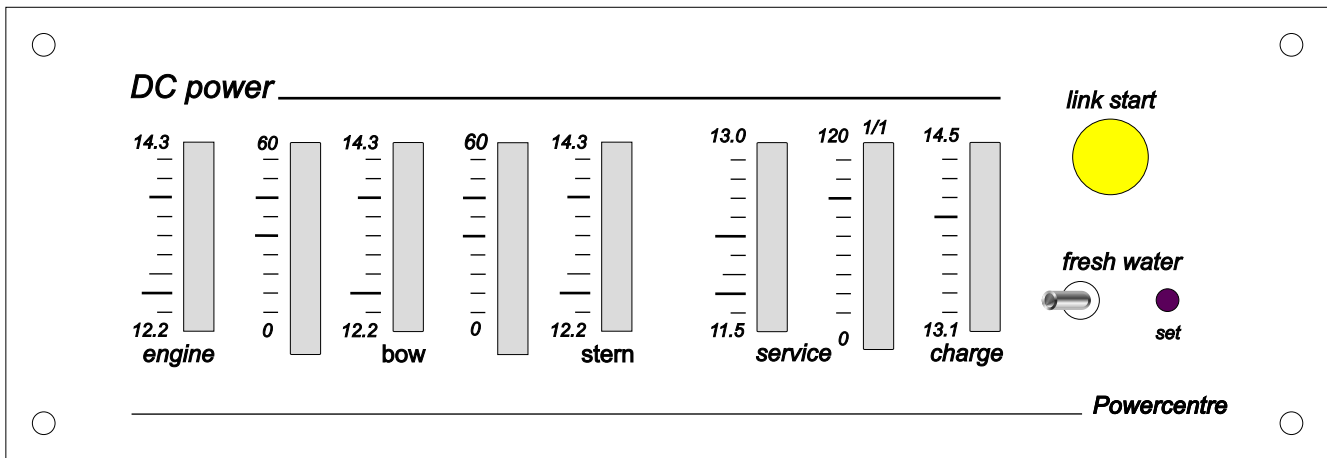

display read-out

service V	service A	engine V	battery level guide	no load	on load
12.90	120	14.30		50%	50%
12.75	90	13.65		100%	100%
12.50	60	13.20			
12.45	40	12.90	red LED		
12.30	30	12.65			
12.15	20	12.50			
12.00	14	12.40			
11.85	10	12.30			
11.70	8	12.25			
11.55	6	12.20			

display options

The bar-graph can be supplied to order with alternate display values to suit a particular charging system, see **display options** allowing the display to be matched to the intended use,

logarithmic scale provides a extended scale in the low half, allowing low current monitoring of the completion of charge, or current drain during use. While the initial high charge current can be monitored on the upper high section.

linear scale, is used for monitoring charge current, or high discharge loads, the meter scale is uniform over the full meter range.

digital readout for all functions can be supplied to supplement the bar-graph display, allowing detail examination of volts or amps.

For non standard options please contact technical section.

alternate display scaling

log scale		linear scale	
60	240	100	200
45	175	90	180
30	125	80	160
20	80	70	140
15	60	60	120
10	40	50	100
7	28	40	80
5	20	30	60
4	16	20	40
3	12	10	20

data sheet twin engine emergency link start systems

emergency link starting

Emergency link start allows an engine with low battery capacity to link to another battery bank to improve or provide starting. The one problem using the service battery is low voltage from starter motor power draw, and the spikes generated by the starter motor. This can have serious problems with electronic equipment and system memory.

With twin engine installation that use two engine battery banks, by linking these for emergency starting a clean power supply is maintained for the service power supply.

Start the good engine, press the link button to close the link contactor for 2 minutes, allowing the engine with the low battery to start from the other battery bank. Coil power supply is optimised by drawing power from all battery banks available.

Normally a low battery would not be a problem as the bar-graph display would have provided advanced warning of a low engine battery, allowing the fault to be corrected.

Twin engine external link start

The external link start contactor is connected between the battery isolators, making the connecting cable length a minimum, reducing both cost and volt drop.

This system is also used where the charge cables to the split charge module are too small for the starter motor current.

Control connection is a 2 core cable between contactor and split charge control module.

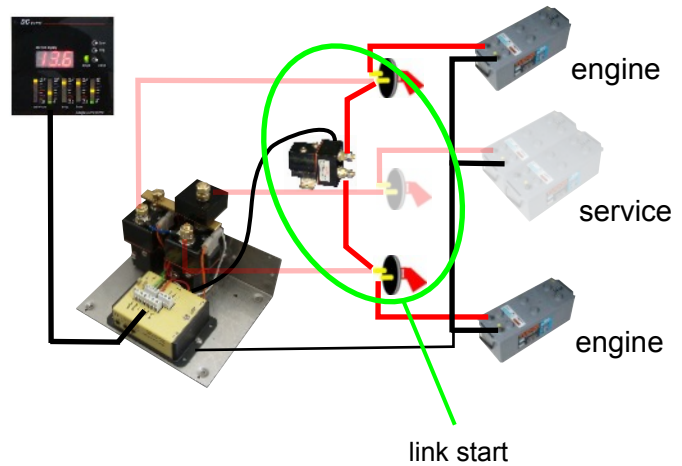

Twin engine, internal link start

The internal link start contactor is pre-wired between the input feeds from engine battery isolators. Control of the link contactor is also pre-wired, making this a very simple installation.

The critical point with this system is that all power cables are of a rating suitable for the starter motor load.

