

data sheet

P2300 twin engine two battery bank split charge system

12 volt P2300	part number 12300-000	continuous 100 amp @ 50 mV engine start 250 amp intermittent surge 500 amp
12 volt P2330	part number 12330-000	continuous 200 amp @ 40 mV / contact / 100 A engine start 400 amp intermittent
24 volt P2340	part number 12340-000	surge 800 amp

operation bi-directional split charge, standard
connect voltage 13.8V
drop-out voltage 13.0V
adjustment contactor engagement and drop out
protection waterproof to IP66
emergency link start ... includes button to engage link start timed period.
system protection ... 3 internal PTC fuses, auto re-set
size / weight 70 x 80 x 100 mm / 400 gms
70 x 80 x 100 mm / 500 gms

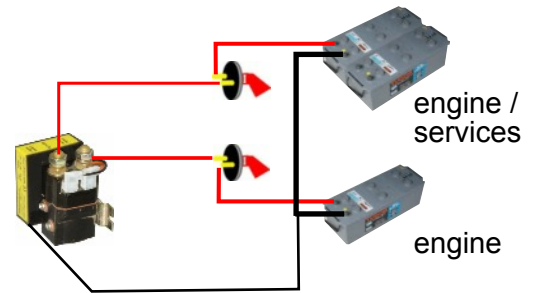

P2400 twin engine three battery bank split charge system

12 volt P2400	part number 12400-000	continuous 100 amp @ 50 mV engine start 250 amp intermittent surge 500 amp
12 volt P2430	part number 12430-000	continuous 200 amp @ 40 mV / contact / 100 A engine start 400 amp intermittent
24 volt P2440	part number 12440-000	surge 800 amp

operation bi-directional split charge, standard
connect voltage 13.8V
drop-out voltage 13.0V
adjustment relay engagement and drop out
protection waterproof to IP66
emergency link start ... includes button to engage link start timed period.
system protection ... 4 internal PTC fuses, auto re-set
size / weight 175 x 150 x 135 mm / 1.3Kgs
175 x 150 x 135 mm / 1.9Kgs

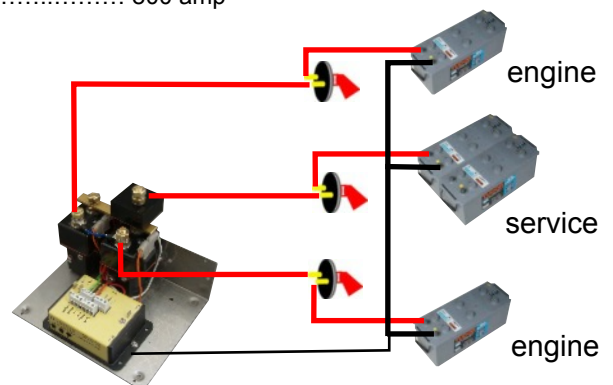

data sheet

P2500 twin engine four battery bank split charge system

12 volt P2500 part number 12500-000 continuous 100 amp @ 50 mV
 engine start 250 amp intermittent
 surge 500 amp

12 volt P2530 part number 12530-000 continuous 200 amp @ 40 mV / contact / 100 A
24 volt P2540 part number 12540-000 engine start 400 amp intermittent
 surge 800 amp

operation bi-directional split charge, standard
 connect voltage 13.8V
 drop-out voltage 13.0V
 adjustment contactor engagement and drop out
 protection waterproof to IP66
 ammeter shunt 2 integral Hall effect shunts
 emergency link start ... includes button to engage link start timed period.

system protection .. 5 internal PTC fuses, auto re-set

size / weight 175 x 150 x 135 mm / 1.3Kgs
 175 x 150 x 135 mm / 1.5Kgs

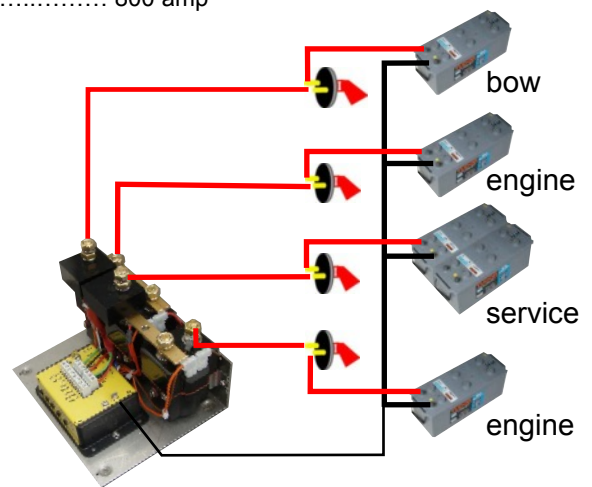

P2800 twin engine, four bank, start, service, bow and stern

12 volt P2800 part number 12800-000 continuous 100 amp @ 50 mV
 engine start 250 amp intermittent
 surge 500 amp

12 volt P2830 part number 12830-000 continuous 200 amp @ 40 mV / contact / 100 A
24 volt P2840 part number 12840-000 engine start 400 amp intermittent
 surge 800 amp

operation bi-directional split charge, standard
 connect voltage bow .. 13.8V stern 13.9V
 drop-out voltage 13.0V
 adjustment contactor engagement and drop out
 protection waterproof to IP66
 emergency link start ... includes button to engage link start timed period.

system protection .. 5 internal PTC fuses, auto re-set

size / weight 175 x 140 x 135 mm / 1.3Kgs
 175 x 140 x 135 mm / 1.9Kgs

